

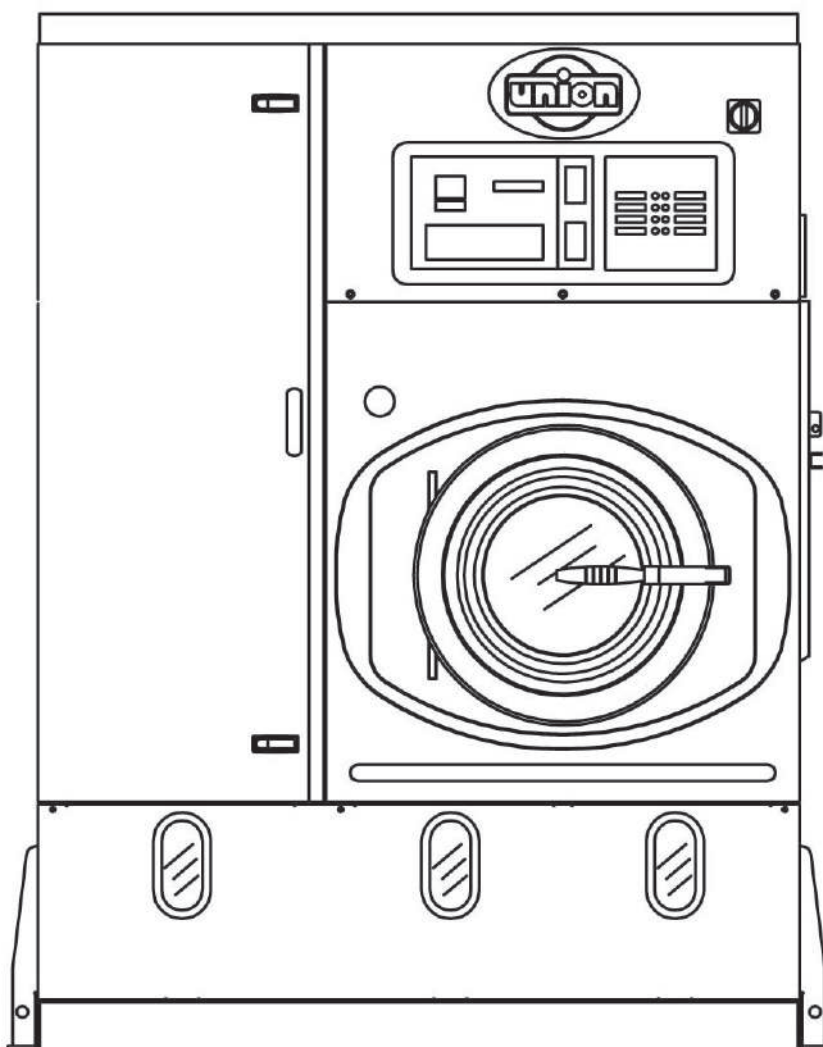

TECHNICAL INFORMATION



HXL8015S-K



WORKING MACHINE WITH SOLVENT	HYDROCARBON / GREEN EARTH / SOLVON K4	
MACHINE CAPACITY	15 Kg	35 Lbs

BASKET		
Diameter	800 mm	<i>31.5 inches</i>
Depth	560 mm	<i>22 inches</i>
Volume	285 Lt	<i>10.1 cu.ft</i>
Wash speed	20 ÷ 55 rpm	
Extract speed	300 ÷ 500 rpm	
Door opening	500 mm	<i>19.7 inches</i>

SOLVENT TANKS		
Useful volume tank 1	105 Lt	<i>28 gal</i>
Useful volume tank 2	105 Lt	<i>28 gal</i>
Useful volume tank 3	120 Lt	<i>32 gal</i>
FLOOR SAFETY TANK CAPACITY	210 Lt	<i>55.5 gal</i>

STILL		
Useful volume at half inspection	145 Lt	<i>38.3 gal</i>
Total volume	180 Lt	<i>47.6 gal</i>
Boiler water capacity	4.6 Lt	<i>1.2 gal</i>

ELECTRIC POWER	400 V - 50HZ		220 V - 60HZ	
Wash - Extract (With Inverter)	*0.8÷4 Hp	*0.6÷3 Kw	<i>*0.8÷4 Hp</i>	<i>*0.6÷3 Kw</i>
Solvent pump motor	0.75 Hp	0.55 Kw	<i>0.75 Hp</i>	<i>0.55 Kw</i>
Fan motor	2 Hp	1.5 Kw	<i>2 Hp</i>	<i>1.5 Kw</i>
Refrigerator compressor (Bristoll)	3.35 Hp	2.5 Kw	<i>3.35 Hp</i>	<i>2.5 Kw</i>
Nylon filter motor	0.75 Hp	0.55 Kw	<i>0.75 Hp</i>	<i>0.55 Kw</i>
Vacuum pump motor	0.5 Hp	0.38 Kw	<i>0.5 Hp</i>	<i>0.38 Kw</i>
Still electric elements	-	9 Kw	-	<i>9 Kw</i>
Heater electric elements	-	9 Kw	-	<i>9 Kw</i>
Air motor compressor (optional)	0.5 Hp	0.38 Kw	-	-
Button trap drying blower	0.75 Hp	0.55 Kw	<i>0.75 Hp</i>	<i>0.55 Kw</i>

* POWER CHANGES ACCORDINGLY TO THE USE OF THE MACHINE

NOTE: Acoustic emission level of the machine is lower than 70 dB (A)

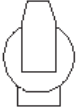

FILTRATION AVAILABLE IN THIS MODEL

ONE NYLON FILTER			
	Volume nylon filter housing	35 Lt	<i>9.2 gal</i>
	Nylon filter area	2.1 mt²	<i>22.6 ft²</i>
	Filter disks	14 nr	

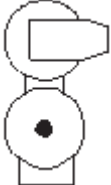
ONE NYLON FILTER AND ONE LARGE CARTRIDGE - KR			
	Volume nylon filter housing	35 Lt	<i>9.2 gal</i>
	Nylon filter area	2.1 mt²	<i>22.6 ft²</i>
	Filter disks	14 nr	
	Vol. large cartridge housing KR	35 Lt	<i>9.2 gal</i>
	Area large cartridge KR	2.6 mt²	<i>28 ft²</i>
	Cartridges quantity KR	nr 1	

TWO NYLON FILTER			
	Volume nylon filter housing	35x2=70 Lt	<i>9.2x2=18.4 gal</i>
	Nylon filter area	2.1x2=4.2 mt²	<i>22.6x2=45.2 ft²</i>
	Filter disks	14x2=28 nr	

ONE NYLON FILTER AND ONE DECOLORATING FILTER PR			
	Volume nylon filter housing	35 Lt	<i>9.2 gal</i>
	Nylon filter area	2.1 mt²	<i>22.6 ft²</i>
	Filter disks	14 nr	
	Decolorating housing volume PR	13 Lt	<i>3,4 gal</i>
	Decolorating cartridges	1 nr	
	Decolorating cabon quantity	2 kg	<i>4,4 Lbs</i>



DIMENSIONS AND WEIGHTS

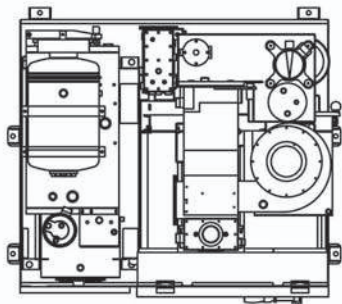
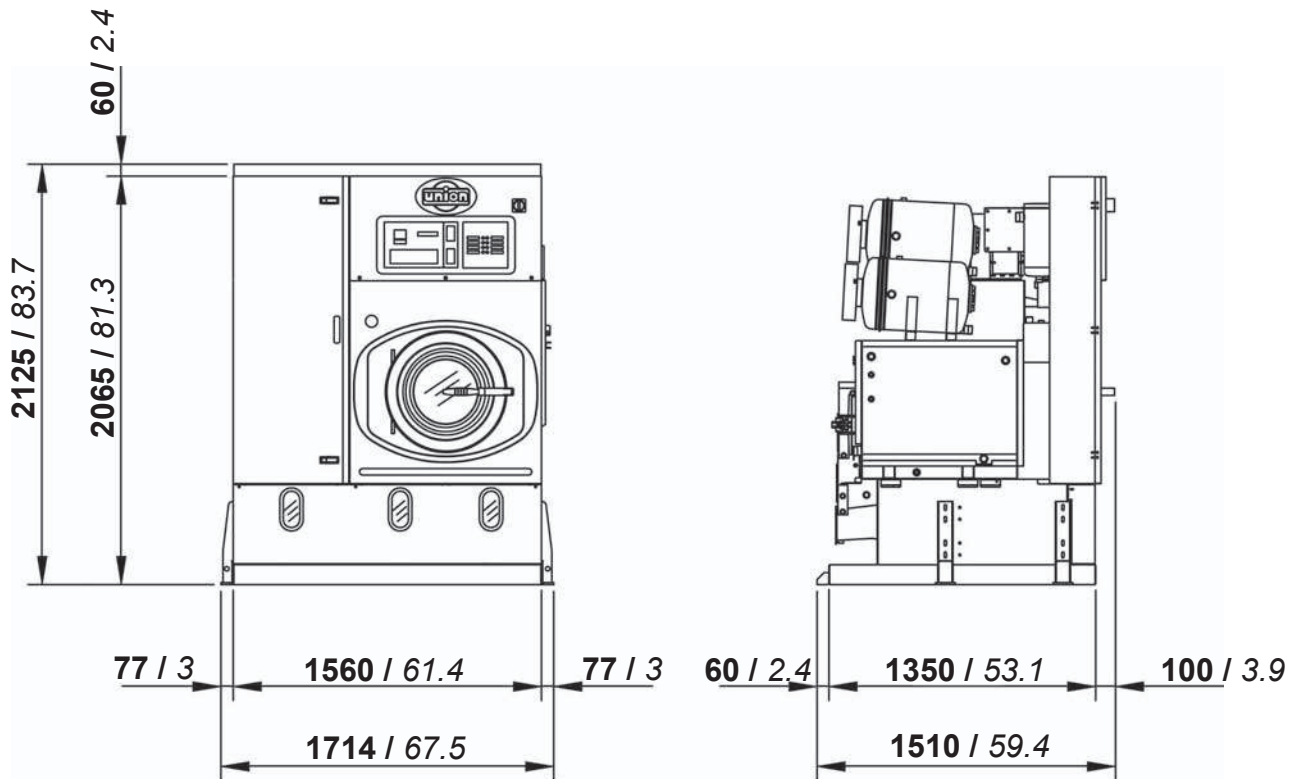

mm / inches

CHARGES		
Empty machine weight	1340 Kg	2954 Lbs
Machine weight with solvent	1650 Kg	3637 Lbs
Static charge on the floor with solvent	783 Kg/m²	160 Lbs/ft ²
Dynamic charge on the floor (+10%)	1130 Kg/m²	231 Lbs/ft ²



PACKAGED MACHINE DIMENSIONS AND WEIGHTS

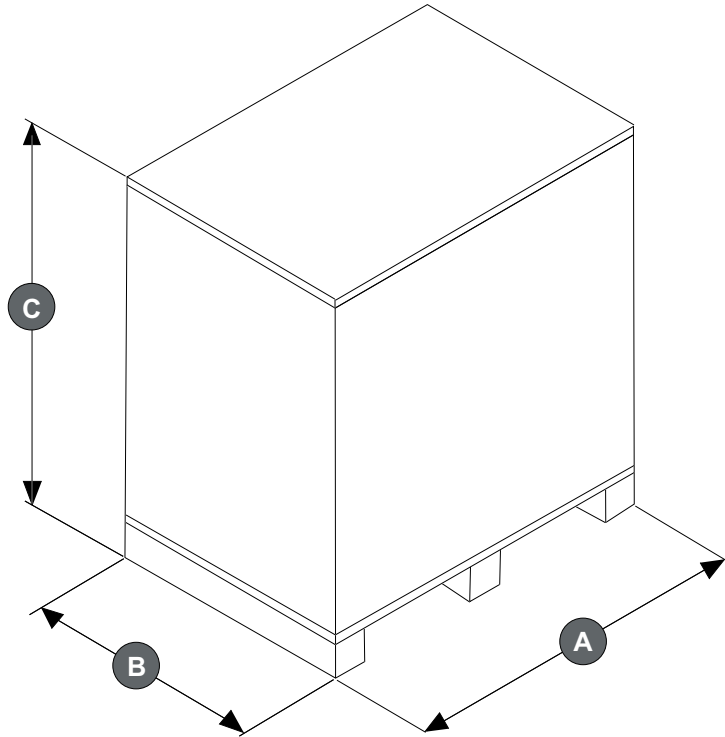

PACKAGED MACHINE DIMENSIONS

Machine type		Carton		Wooden cage		Wooden case	
Standard	A	1760 mm	69.3 inches	- mm	- inches	- mm	- inches
	B	1580 mm	62.2 inches	- mm	- inches	- mm	- inches
	C	2245 mm	88.4 inches	- mm	- inches	- mm	- inches

PACKAGED MACHINE WEIGHTS

Machine type	Carton		Wooden cage		Wooden case	
Standard	1430 Kg	3153 Lbs	- Kg	- Lbs	- Kg	- Lbs



FIXING POINTS

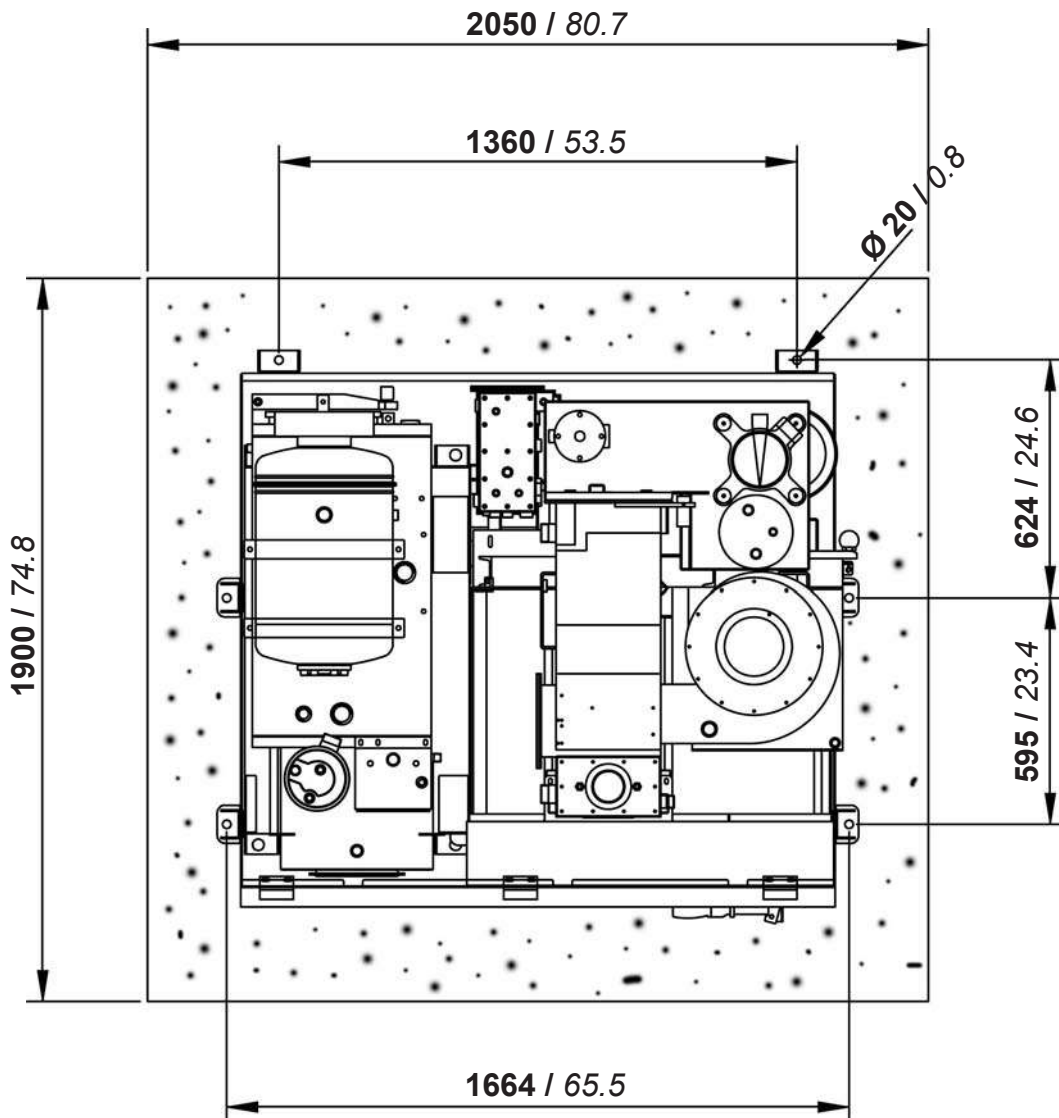
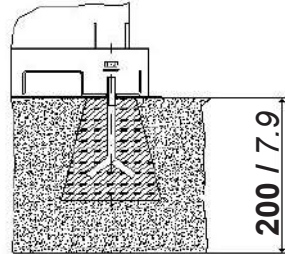

mm / inches



CONNECTIONS

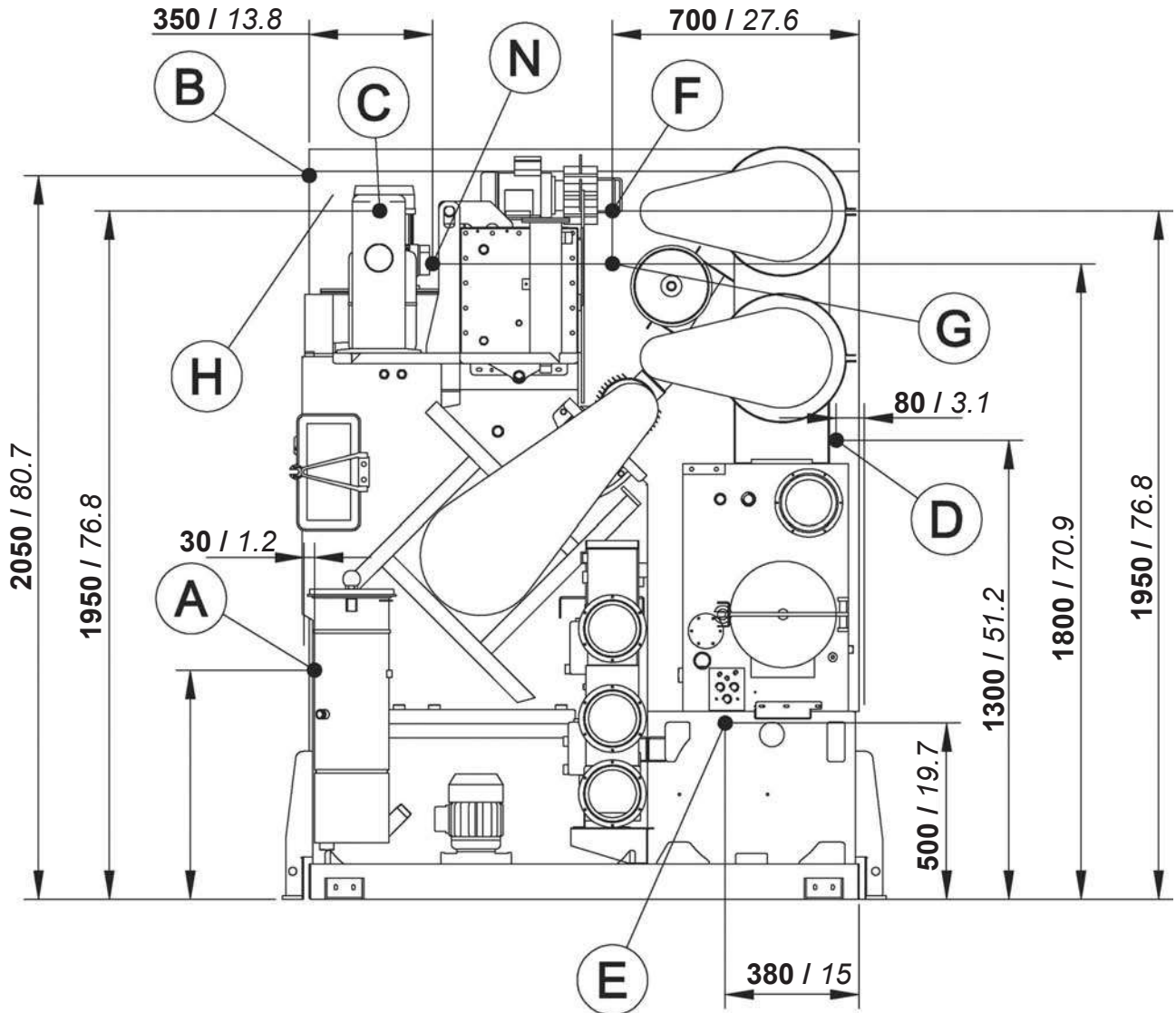

mm / inches

A	Compressed air inlet	Ø 6mm	Ø 1/4"
B	Water inlet	Ø 3/4"	
C	Water outlet	Ø 3/4"	
D	Steam still inlet	Ø 1/2"	
E	Condensate still outlet	Ø 1/2"	
F	Steam heater inlet	Ø 1/2"	
G	Condensate heater outlet	Ø 1/2"	
H	Electric connection		
N	Nitrogen feeding connection (N ₂)		



SOLVENT TYPE	HYDROCARBON / GREEN EARTH / SOLVON K4			
NECESSARY QUANTITY OF SOLVENT TO FILL THE MACHINE				
Machine version - without Filters	330 Lt	255 Kg	<i>87 gal</i>	<i>563 Lbs</i>
Machine version - 1 Nylon Filter	365 Lt	281 Kg	<i>96 gal</i>	<i>619 Lbs</i>
Machine version - 1 Nylon Filter + 1 KR	400 Lt	308 Kg	<i>106 gal</i>	<i>679 Lbs</i>
Machine version - 2 Nylon Filters	400 Lt	308 Kg	<i>106 gal</i>	<i>679 Lbs</i>
Machine version - 1 Nylon Filter + 1 Deco	378 Lt	291 Kg	<i>100 gal</i>	<i>641Lbs</i>

INFORMATION FOR THE ELECTRICAL CONNECTIONS (400 V - 50 Hz)		
ELECTRIC Version	24 Kw	40 Amp
STEAM Version	6.5 Kw	19 Amp
Dissipated heat	4334 Kcal	

INFORMATION FOR THE ELECTRICAL CONNECTIONS (220 V - 60 Hz)		
ELECTRIC Version	<i>- Kw</i>	<i>- Amp</i>
STEAM Version	6.5 Kw	32 Amp
Dissipated heat	<i>- Kcal</i>	

GENERAL INFORMATION		
Required water capacity	Lt/min 10	<i>gal/min 2.6</i>
Required water pressure	bar 2 ÷ 3	<i>psi 29 ÷ 44</i>
Required water temperature	°C 18 ÷ 23	<i>°F 65 ÷ 73</i>
Required air pressure	bar 7 ÷ 8	<i>psi 100 ÷ 115</i>
Required steam pressure (Steam Version)	bar 4 ÷ 5	<i>psi 55 ÷ 70</i>
Required steam availability	Kg/h 40	<i>Lbs/h 88</i>

All technical data are subject to change without notice.