

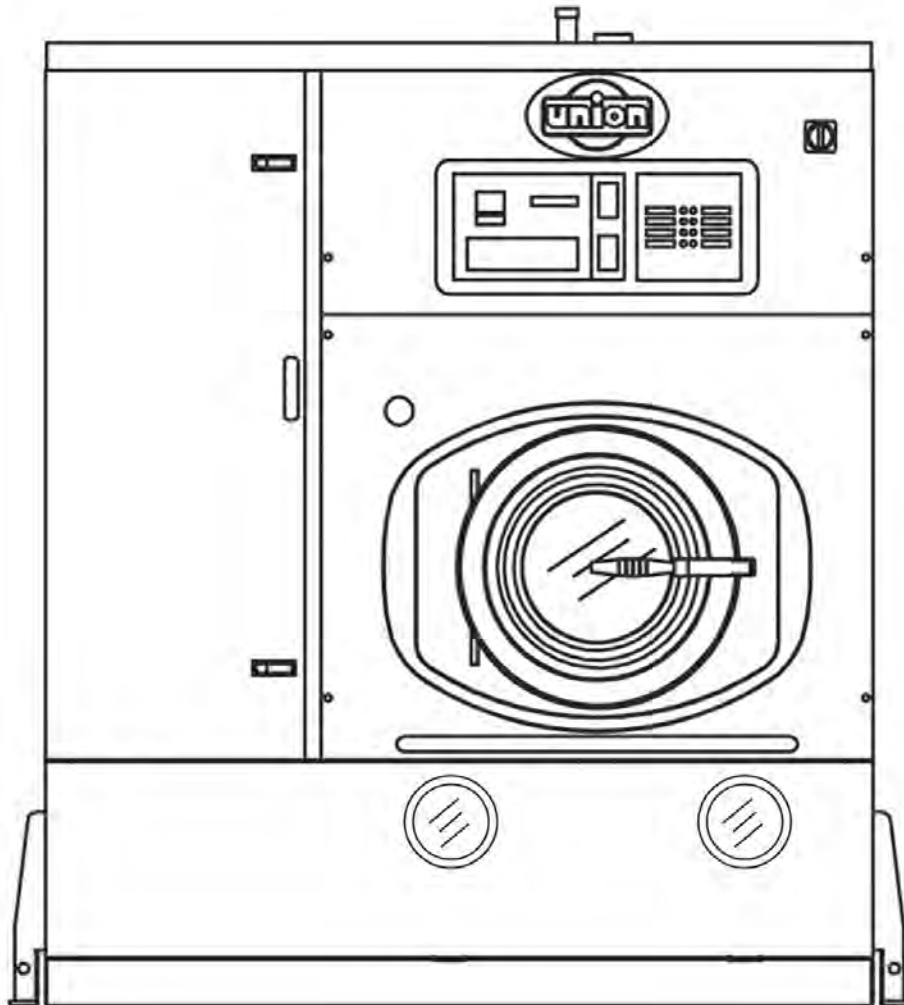

## TECHNICAL INFORMATION



# HXL8018E-K



<b>MACHINE CAPACITY</b>	<b>18 Kg</b>	<b>40 Lbs</b>
-------------------------	--------------	---------------

<b>BASKET</b>		
Diameter	<b>900 mm</b>	<i>35.4 inches</i>
Depth	<b>535 mm</b>	<i>21 inches</i>
Volume	<b>340 Lt</b>	<i>12 cu.ft</i>
Wash speed	<b>20 ÷ 50 rpm</b>	
Extract speed	<b>300 ÷ 520 rpm</b>	
Door opening	<b>500 mm</b>	<i>20 inches</i>

<b>SOLVENT TANKS</b>		
Useful volume tank 1	<b>118 Lt</b>	<i>31 gal</i>
Useful volume tank 2	<b>118 Lt</b>	<i>31 gal</i>
Useful volume tank 3	-	-
<b>FLOOR SAFETY TANK CAPACITY</b>	<b>230 Lt</b>	<i>61 gal</i>

<b>STILL</b>		
Useful volume at half inspection	<b>145 Lt</b>	<i>38.3 gal</i>
Total volume	<b>180 Lt</b>	<i>47.6 gal</i>
Boiler water capacity	<b>4.6 Lt</b>	<i>1.2 gal</i>

<b>ELECTRIC POWER</b>	<b>400V - 3~50Hz</b>		<b>220V - 3~60Hz</b>	
Wash - Extract (With Inverter)	<b>*1.7÷4.7 Hp</b>	<b>*1.3÷3.5 Kw</b>	<i>*1.7÷4.7 Hp</i>	<i>*1.3÷3.5 Kw</i>
Solvent pump motor	<b>1 Hp</b>	<b>0.75 Kw</b>	<i>1 Hp</i>	<i>0.75 Kw</i>
Fan motor	<b>2 Hp</b>	<b>1.5 Kw</b>	<i>3.5 Hp</i>	<i>2.65 Kw</i>
Refrigerator compressor	<b>5.7 Hp</b>	<b>4.26 Kw</b>	<i>7 Hp</i>	<i>5.26 Kw</i>
Nylon filter motor	<b>0.75 Hp</b>	<b>0.55 Kw</b>	<i>0.75 Hp</i>	<i>0.55 Kw</i>
Vacuum pump motor	<b>0.5-1 Hp</b>	<b>0.38-0.75 Kw</b>	<i>0.5-1.2 Hp</i>	<i>0.38-0.90 Kw</i>
Still electric elements	-	<b>9 Kw</b>	-	<i>9 Kw</i>
Heater electric elements	-	<b>12 Kw</b>	-	<i>12 Kw</i>
Air motor compressor (optional)	<b>0.5 Hp</b>	<b>0.38 Kw</b>	<i>0.5 Hp</i>	<i>0.38 Kw</i>

\* POWER CHANGES ACCORDINGLY TO THE USE OF THE MACHINE

NOTE: Acoustic emission level of the machine is lower than 70 dB (A)

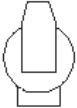

**FILTRATION AVAILABLE IN THIS MODEL**

<b>ONE NYLON FILTER</b>			
	Volume nylon filter housing	<b>55 Lt</b>	<i>14.5 gal</i>
	Nylon filter area	<b>3,9 mt²</b>	<i>42 ft²</i>
	Filter disks	<b>26 nr</b>	

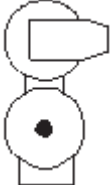
<b>ONE NYLON FILTER AND ONE LARGE CARTRIDGE - KR</b>			
	Volume nylon filter housing	<b>55 Lt</b>	<i>14.5 gal</i>
	Nylon filter area	<b>3,9 mt²</b>	<i>42 ft²</i>
	Filter disks	<b>26 nr</b>	
	Vol. large cartridge housing KR	<b>55 Lt</b>	<i>14.5 gal</i>
	Area large cartridge KR	<b>2,6x2=5,2 mt²</b>	<i>28x2=56 ft²</i>
	Cartridges quantity KR	<b>nr 2</b>	

<b>TWO NYLON FILTER</b>			
	Volume nylon filter housing	<b>55x2=110 Lt</b>	<i>137.4 gal</i>
	Nylon filter area	<b>3,9x2=7,8 mt²</b>	<i>42x2=84 ft²</i>
	Filter disks	<b>26x2=52 nr</b>	

<b>ONE NYLON FILTER AND ONE DECOLORATING FILTER PR</b>			
	Volume nylon filter housing	<b>55 Lt</b>	<i>14.5 gal</i>
	Nylon filter area	<b>3,9 mt²</b>	<i>42 ft²</i>
	Filter disks	<b>26 nr</b>	
	Decolorating housing volume PR	<b>13 Lt</b>	<i>3.4 gal</i>
	Decolorating cartridges	<b>1 nr</b>	
	Decolorating cabon quantity	<b>2 kg</b>	<i>4.4 Lbs</i>



<b>ONE NYLON ONE CARTRIDGE -KR ONE DECOLORATING</b>			
	Volume nylon filter housing	<b>55 Lt</b>	<i>14.5 gal</i>
	Nylon filter area	<b>3,9 mt²</b>	<i>42 ft²</i>
	Filter disks	<b>26 nr</b>	
	Vol. large cartridge housing KR	<b>55 Lt</b>	<i>14.5 gal</i>
	Area large cartridge KR	<b>2,6x2=5,2 mt²</b>	<i>28x2=56 ft²</i>
	Cartridges quantity KR	<b>nr 2</b>	
	Decolorating housing volume	<b>13 Lt</b>	<i>3.4 gal</i>
	Tubes	<b>1 nr</b>	
	Decolorating cartridges	<b>1 nr</b>	
	Decolorating cabon quantity	<b>2 kg</b>	<i>4.4 Lbs</i>

<b>TWO NYLON FILTERS AND ONE DECOLORATING FILTER</b>			
	Volume nylon filter housing	<b>55x2=110 Lt</b>	<i>137.4 gal</i>
	Nylon filter area	<b>3,9x2=7,8 mt²</b>	<i>42x2=84 ft²</i>
	Filter disks	<b>26x2=52 nr</b>	
	Decolorating housing volume	<b>13 Lt</b>	<i>3.4 gal</i>
	Tubes	<b>1 nr</b>	
	Decolorating cartridges	<b>1 nr</b>	
	Decolorating cabon quantity	<b>2 kg</b>	<i>4.4 Lbs</i>

<b>TWO NYLON FILTER AND TWO DECOLORATING FILTER</b>			
	Volume nylon filter housing	<b>55x2=110 Lt</b>	<i>137.4 gal</i>
	Nylon filter area	<b>3,9x2=7,8 mt²</b>	<i>42x2=84 ft²</i>
	Filter disks	<b>26x2=52 nr</b>	
	Decolorating housing volume	<b>13x2=26 Lt</b>	<i>3.4x2=6.8 gal</i>
	Tubes	<b>2 nr</b>	
	Decolorating cartridges	<b>2 nr</b>	
	Decolorating cabon quantity	<b>4 kg</b>	<i>8.8 Lbs</i>



**DIMENSIONS AND WEIGHTS**

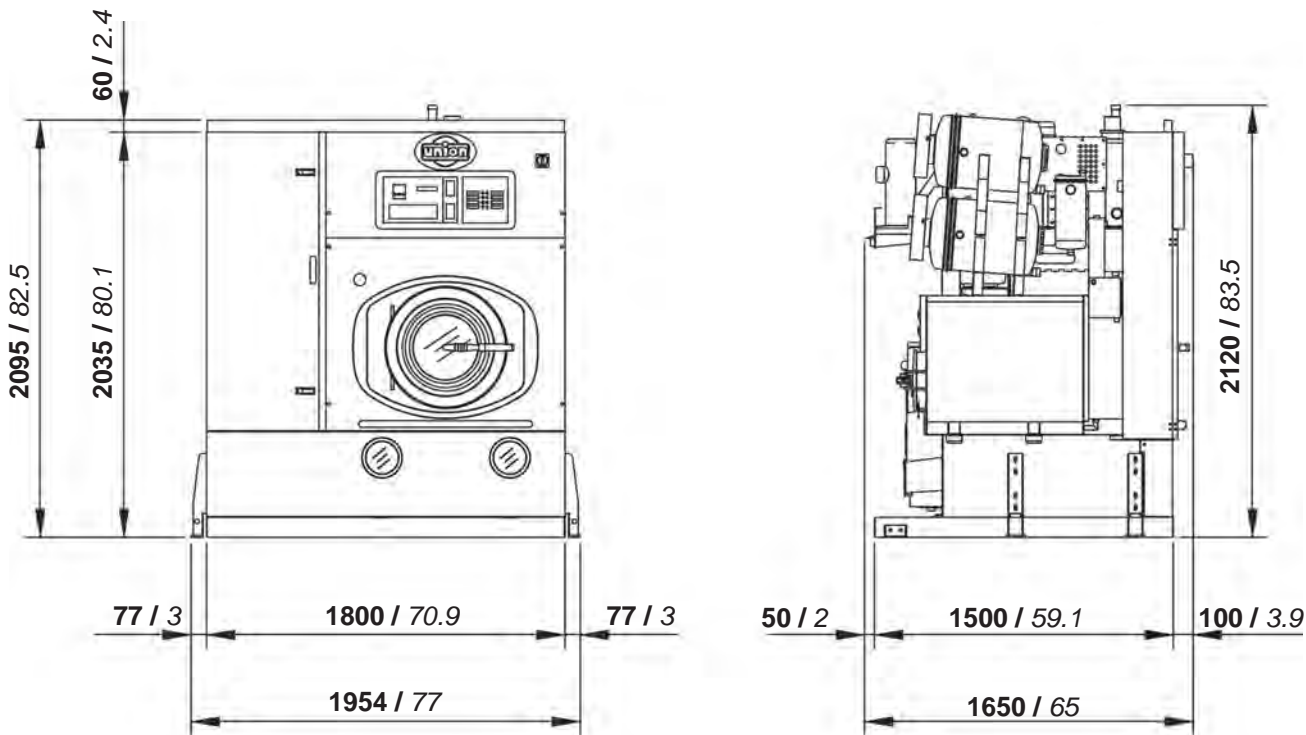

mm / inches

<b>CHARGES</b>		
Empty machine weight	<b>1650 Kg</b>	<b>3634 Lbs</b>
Machine weight with solvent	<b>1935 Kg</b>	<b>4266 Lbs</b>
Static charge on the floor with solvent	<b>717 Kg/m<sup>2</sup></b>	<b>147 Lbs/ft<sup>2</sup></b>
Dynamic charge on the floor (+10%)	<b>1095 Kg/m<sup>2</sup></b>	<b>224 Lbs/ft<sup>2</sup></b>



**PACKAGED MACHINE DIMENSIONS AND WEIGHTS**

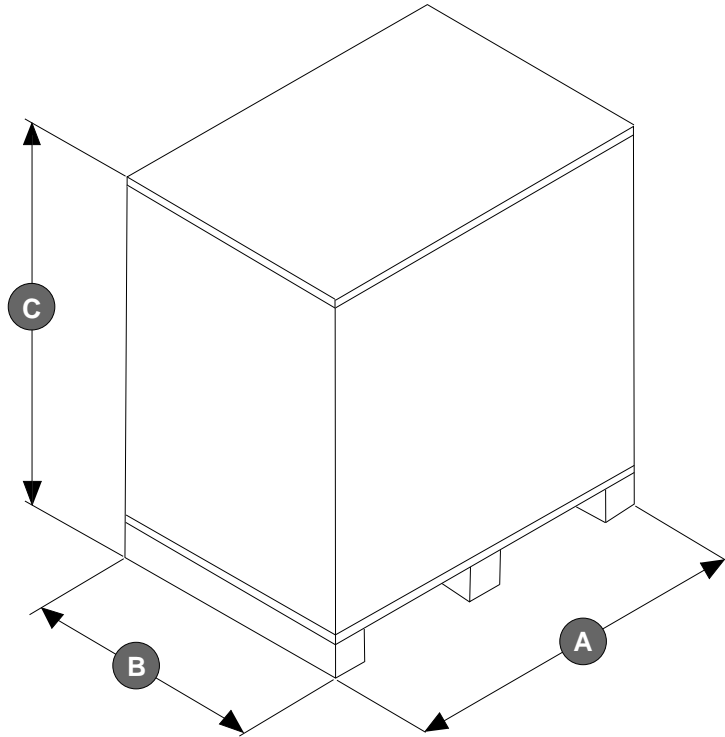

PACKAGED MACHINE DIMENSIONS							
Machine type		Carton		Wooden cage		Wooden case	
<b>Standard</b>	<b>A</b>	- mm	- inches	- mm	- inches	- mm	- inches
	<b>B</b>	- mm	- inches	- mm	- inches	- mm	- inches
	<b>C</b>	- mm	- inches	- mm	- inches	- mm	- inches

PACKAGED MACHINE WEIGHTS						
Machine type	Carton		Wooden cage		Wooden case	
<b>Standard</b>	- Kg	- Lbs	- Kg	- Lbs	- Kg	- Lbs



FIXING POINTS

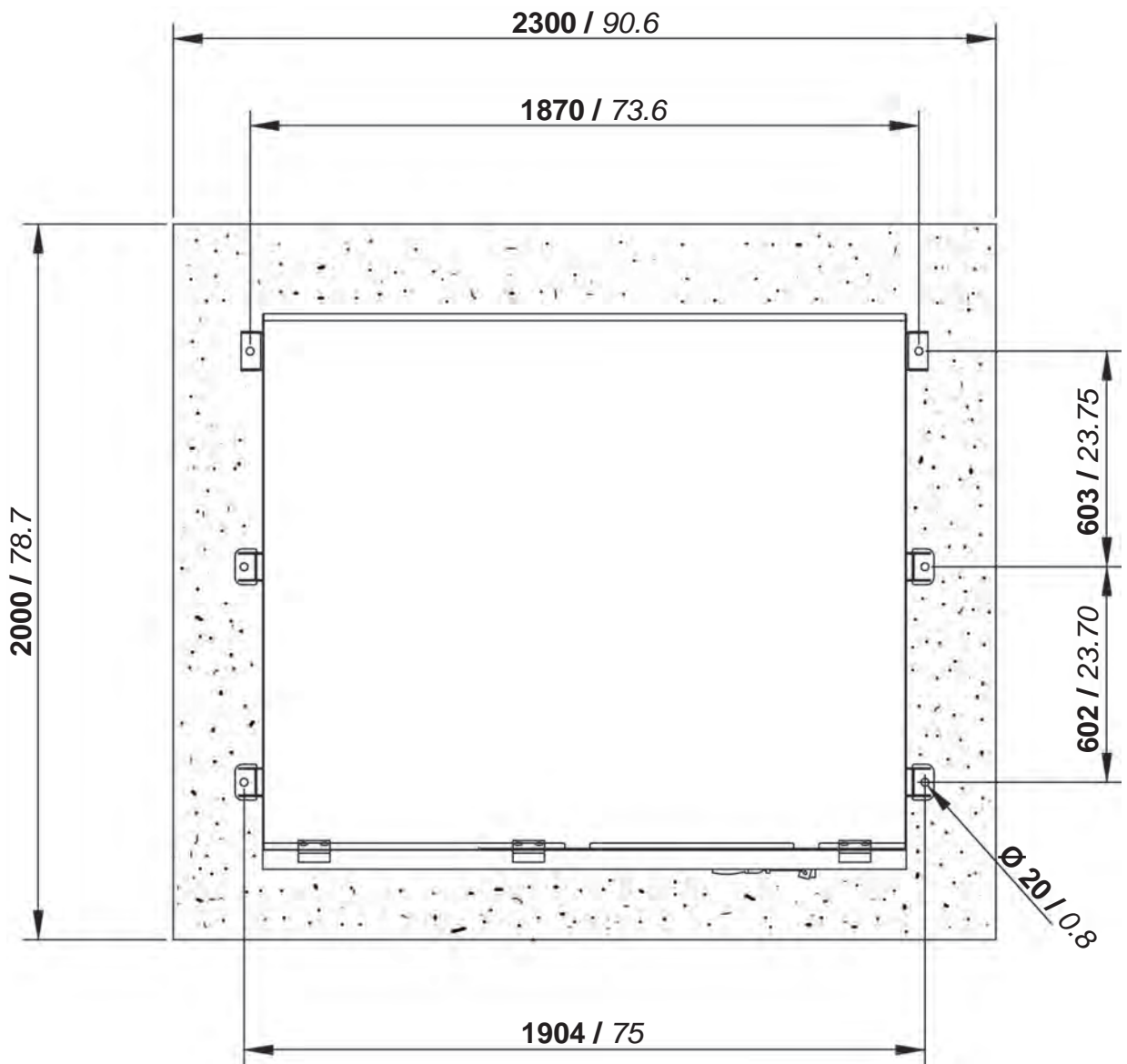
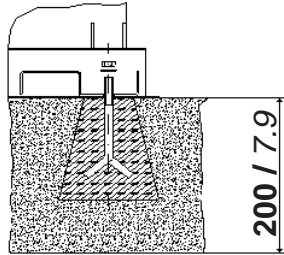

mm / inches



CONNECTIONS

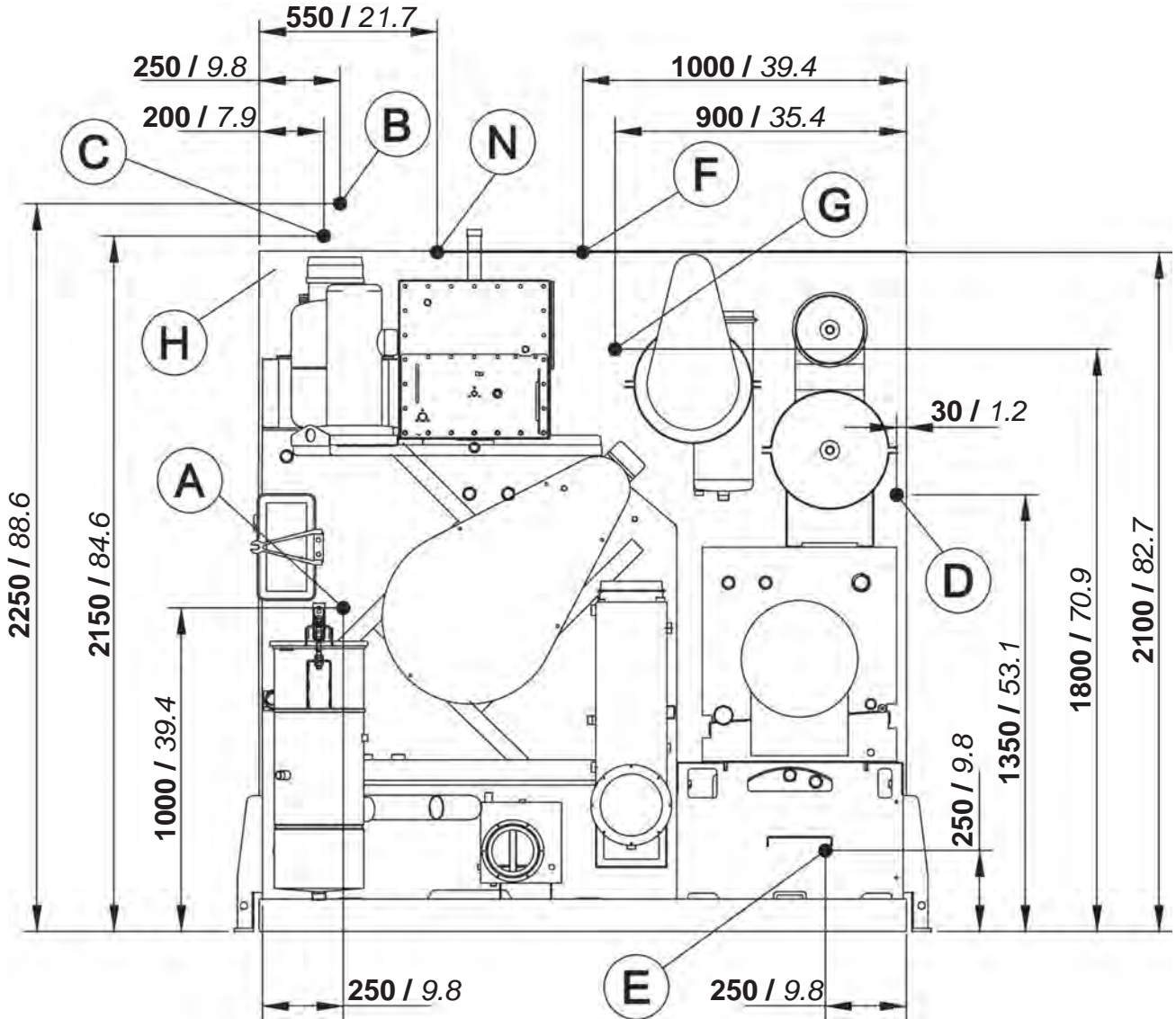

mm / inches

A	Compressed air inlet	Ø 6mm	Ø 1/4"
B	Water inlet	Ø 3/4"	
C	Water outlet	Ø 3/4"	
D	Steam still inlet	Ø 1/2"	
E	Condensate still outlet	Ø 1/2"	
F	Steam heater inlet	Ø 1/2"	
G	Condensate heater outlet	Ø 1/2"	
H	Electric connection		
N	Nitrogen feeding connection (N <sub>2</sub> )		





<b>NECESSARY QUANTITY OF SOLVENT TO FILL THE MACHINE</b>				
Machine version - without Filters	<b>236 Lt</b>	<b>182 Kg</b>	<i>62 gal</i>	<i>401 Lbs</i>
Machine version - 1 Nylon Filter	<b>291 Lt</b>	<b>224 Kg</b>	<i>77 gal</i>	<i>494 Lbs</i>
Machine version - 1 Nylon Filter + 1 KR	<b>346 Lt</b>	<b>266 Kg</b>	<i>91 gal</i>	<i>586 Lbs</i>
Machine version - 2 Nylon Filters	<b>346 Lt</b>	<b>266 Kg</b>	<i>91 gal</i>	<i>586 Lbs</i>
Machine version - 1 Nylon Filter + 1 Deco	<b>304 Lt</b>	<b>234 Kg</b>	<i>80 gal</i>	<i>516 Lbs</i>
Machine version - 1 Nylon Filter + 1 KR + 1 Deco	<b>359 Lt</b>	<b>276 Kg</b>	<i>95 gal</i>	<i>608 Lbs</i>
Machine version - 2 Nylon Filters + 1 Deco	<b>359 Lt</b>	<b>276 Kg</b>	<i>95 gal</i>	<i>608 Lbs</i>
Machine version - 2 Nylon Filters + 2 Deco	<b>372 Lt</b>	<b>286 Kg</b>	<i>98 gal</i>	<i>631 Lbs</i>

<b>INFORMATION FOR THE ELECTRICAL CONNECTIONS (400V - 3~50Hz)</b>		
ELECTRIC Version	<b>29.5 Kw</b>	<b>50 Amp</b>
STEAM Version	<b>8.5 Kw</b>	<b>18 Amp</b>
Dissipated heat	<b>5300 Kcal</b>	

<b>INFORMATION FOR THE ELECTRICAL CONNECTIONS (220V - 3~60Hz)</b>		
ELECTRIC Version	<i>- Kw</i>	<i>- Amp</i>
STEAM Version	<i>9.5 Kw</i>	<i>30 Amp</i>
Dissipated heat	<i>4600 Kcal</i>	

<b>GENERAL INFORMATION</b>		
Required water capacity	<b>10 Lt/min</b>	<i>2.6 gal/min</i>
Required water pressure	<b>2 ÷ 3 bar</b>	<i>29 ÷ 44 psi</i>
Required water temperature	<b>18 ÷ 23 °C</b>	<i>65 ÷ 73 °F</i>
Required air pressure	<b>7 ÷ 8 bar</b>	<i>100 ÷ 115 psi</i>
Required steam still pressure (K4)	<b>2.5 bar</b>	<i>36 psi</i>
Required steam still pressure	<b>4 ÷ 5 bar</b>	<i>55 ÷ 72 psi</i>
Required steam heater pressure	<b>4 ÷ 5 bar</b>	<i>55 ÷ 72 psi</i>
Required steam* availability	<b>50 Kg/h</b>	<i>110 Lbs/h</i>

\* Relative values of dry saturated steam.

All technical data are subject to change without notice.