

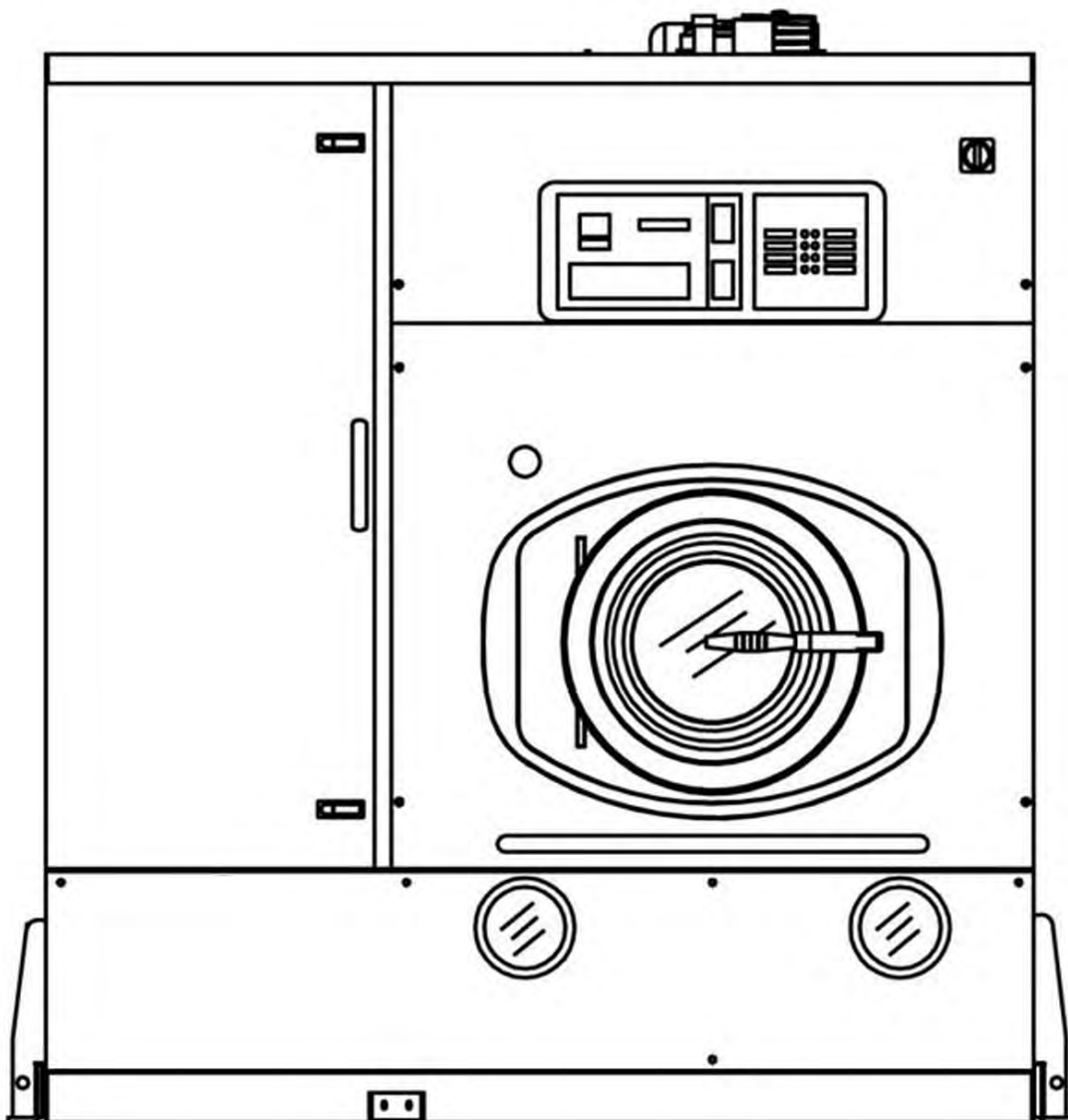

TECHNICAL INFORMATION



HXL8025E-K



MACHINE CAPACITY	25 Kg	55÷60 Lbs
-------------------------	--------------	------------------

BASKET		
Diameter	1000 mm	<i>39.4 inches</i>
Depth	640 mm	<i>25.2 inches</i>
Volume	500 Lt	<i>17.7 cu.ft</i>
Wash speed	20 ÷ 50 rpm	
Extract speed	300 ÷ 520 rpm	
Door opening	500 mm	<i>20 inches</i>

SOLVENT TANKS		
Useful volume tank 1	145 Lt	<i>38 gal</i>
Useful volume tank 2	145 Lt	<i>38 gal</i>
Useful volume tank 3	-	-
FLOOR SAFETY TANK CAPACITY	327 Lt	<i>86 gal</i>

STILL		
Useful volume at half inspection	190 Lt	<i>50 gal</i>
Total volume	230 Lt	<i>61 gal</i>
Boiler water capacity	5 Lt	<i>1.3 gal</i>

ELECTRIC POWER	400V - 3~50Hz		220V - 3~60Hz	
Wash - Extract (With Inverter)	*2.7-7.5 Hp	*2-5.5 Kw	<i>*2.7-7.5 Hp</i>	<i>*2-5.5 Kw</i>
Solvent pump motor	1 Hp	0.75 Kw	<i>1 Hp</i>	<i>0.75 Kw</i>
Fan motor	2 Hp	1.5 Kw	<i>3.5 Hp</i>	<i>2.65 Kw</i>
Refrigerator compressor	5.7 Hp	4.26 Kw	<i>7 Hp</i>	<i>5.26 Kw</i>
Nylon filter motor	0.75 Hp	0.55 Kw	<i>0.75 Hp</i>	<i>0.55 Kw</i>
Vacuum pump motor	0.5-1 Hp	0.38-0.75 Kw	<i>0.5-1.2 Hp</i>	<i>0.38-0.90 Kw</i>
Still electric elements	-	12 Kw	-	<i>12 Kw</i>
Heater electric elements	-	12 Kw	-	<i>12 Kw</i>
Air motor compressor (optional)	0.5 Hp	0.38 Kw	<i>0.5 Hp</i>	<i>0.38 Kw</i>

* POWER CHANGES ACCORDINGLY TO THE USE OF THE MACHINE

NOTE: Acoustic emission level of the machine is lower than 70 dB (A)

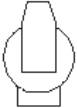

FILTRATION AVAILABLE IN THIS MODEL

ONE NYLON FILTER			
	Volume nylon filter housing	55 Lt	<i>14.5 gal</i>
	Nylon filter area	3,9 mt²	<i>42 ft²</i>
	Filter disks	26 nr	

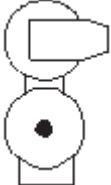
ONE NYLON FILTER AND ONE LARGE CARTRIDGE - KR			
	Volume nylon filter housing	55 Lt	<i>14.5 gal</i>
	Nylon filter area	3,9 mt²	<i>42 ft²</i>
	Filter disks	26 nr	
	Vol. large cartridge housing KR	55 Lt	<i>14.5 gal</i>
	Area large cartridge KR	2,6x2=5,2 mt²	<i>28x2=56 ft²</i>
	Cartridges quantity KR	nr 2	

TWO NYLON FILTER			
	Volume nylon filter housing	55x2=110 Lt	<i>137.4 gal</i>
	Nylon filter area	3,9x2=7,8 mt²	<i>42x2=84 ft²</i>
	Filter disks	26x2=52 nr	

ONE NYLON FILTER AND ONE DECOLORATING FILTER PR			
	Volume nylon filter housing	55 Lt	<i>14.5 gal</i>
	Nylon filter area	3,9 mt²	<i>42 ft²</i>
	Filter disks	26 nr	
	Decolorating housing volume PR	13 Lt	<i>3.4 gal</i>
	Decolorating cartridges	1 nr	
	Decolorating cabon quantity	2 kg	<i>4.4 Lbs</i>



ONE NYLON ONE CARTRIDGE -KR ONE DECOLORATING			
	Volume nylon filter housing	55 Lt	<i>14.5 gal</i>
	Nylon filter area	3,9 mt²	<i>42 ft²</i>
	Filter disks	26 nr	
	Vol. large cartridge housing KR	55 Lt	<i>14.5 gal</i>
	Area large cartridge KR	2,6x2=5,2 mt²	<i>28x2=56 ft²</i>
	Cartridges quantity KR	nr 2	
	Decolorating housing volume	13 Lt	<i>3.4 gal</i>
	Tubes	1 nr	
	Decolorating cartridges	1 nr	
	Decolorating cabon quantity	2 kg	<i>4.4 Lbs</i>

TWO NYLON FILTERS AND ONE DECOLORATING FILTER			
	Volume nylon filter housing	55x2=110 Lt	<i>137.4 gal</i>
	Nylon filter area	3,9x2=7,8 mt²	<i>42x2=84 ft²</i>
	Filter disks	26x2=52 nr	
	Decolorating housing volume	13 Lt	<i>3.4 gal</i>
	Tubes	1 nr	
	Decolorating cartridges	1 nr	
	Decolorating cabon quantity	2 kg	<i>4.4 Lbs</i>

TWO NYLON FILTER AND TWO DECOLORATING FILTER			
	Volume nylon filter housing	55x2=110 Lt	<i>137.4 gal</i>
	Nylon filter area	3,9x2=7,8 mt²	<i>42x2=84 ft²</i>
	Filter disks	26x2=52 nr	
	Decolorating housing volume	13x2=26 Lt	<i>3.4x2=6.8 gal</i>
	Tubes	2 nr	
	Decolorating cartridges	2 nr	
	Decolorating cabon quantity	4 kg	<i>8.8 Lbs</i>



DIMENSIONS AND WEIGHTS

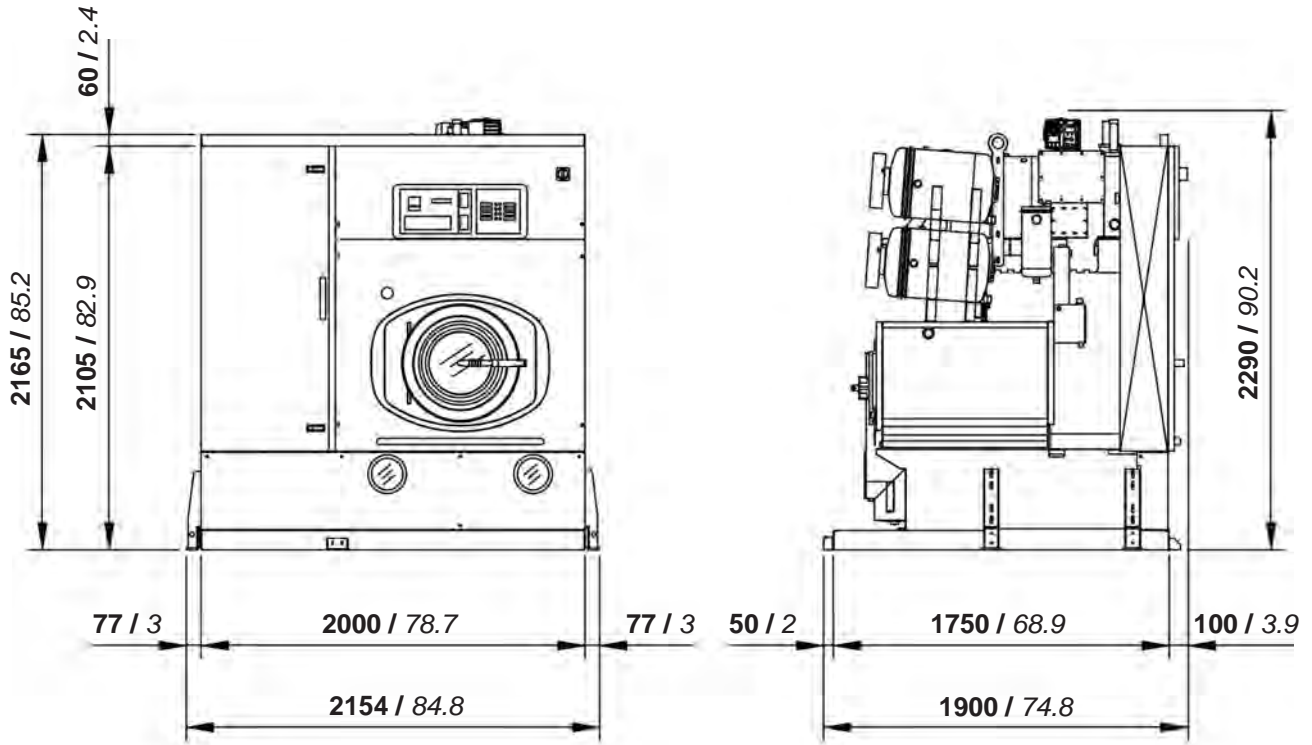

mm / inches

CHARGES		
Empty machine weight	2070 Kg	4564 Lbs
Machine weight with solvent	2397 Kg	5284 Lbs
Static charge on the floor with solvent	685 Kg/m²	140 Lbs/ft²
Dynamic charge on the floor (+10%)	1118 Kg/m²	229 Lbs/ft²



PACKAGED MACHINE DIMENSIONS AND WEIGHTS

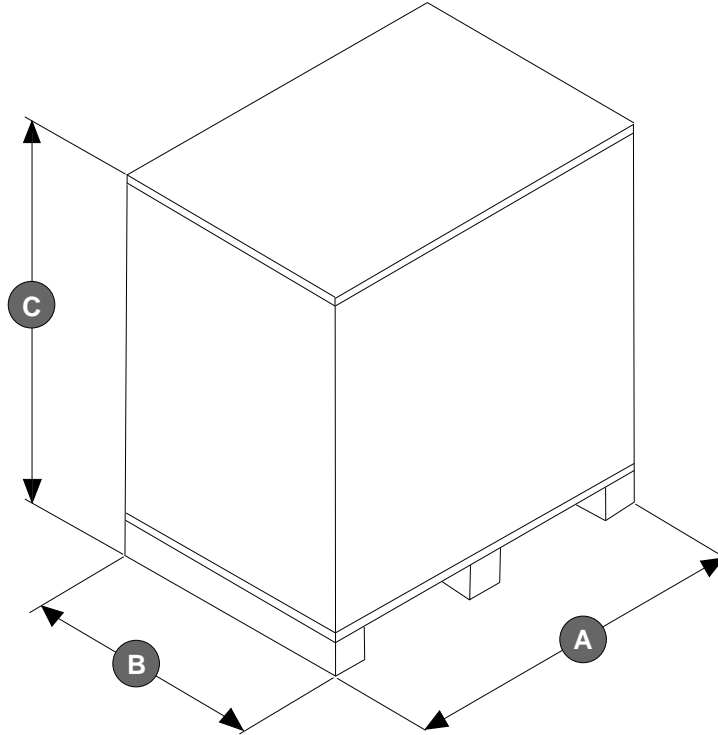

PACKAGED MACHINE DIMENSIONS							
Machine type		Carton		Wooden cage		Wooden case	
Standard	A	- mm	- inches	- mm	- inches	- mm	- inches
	B	- mm	- inches	- mm	- inches	- mm	- inches
	C	- mm	- inches	- mm	- inches	- mm	- inches

PACKAGED MACHINE WEIGHTS						
Machine type	Carton		Wooden cage		Wooden case	
Standard	- Kg	- Lbs	- Kg	- Lbs	- Kg	- Lbs



FIXING POINTS

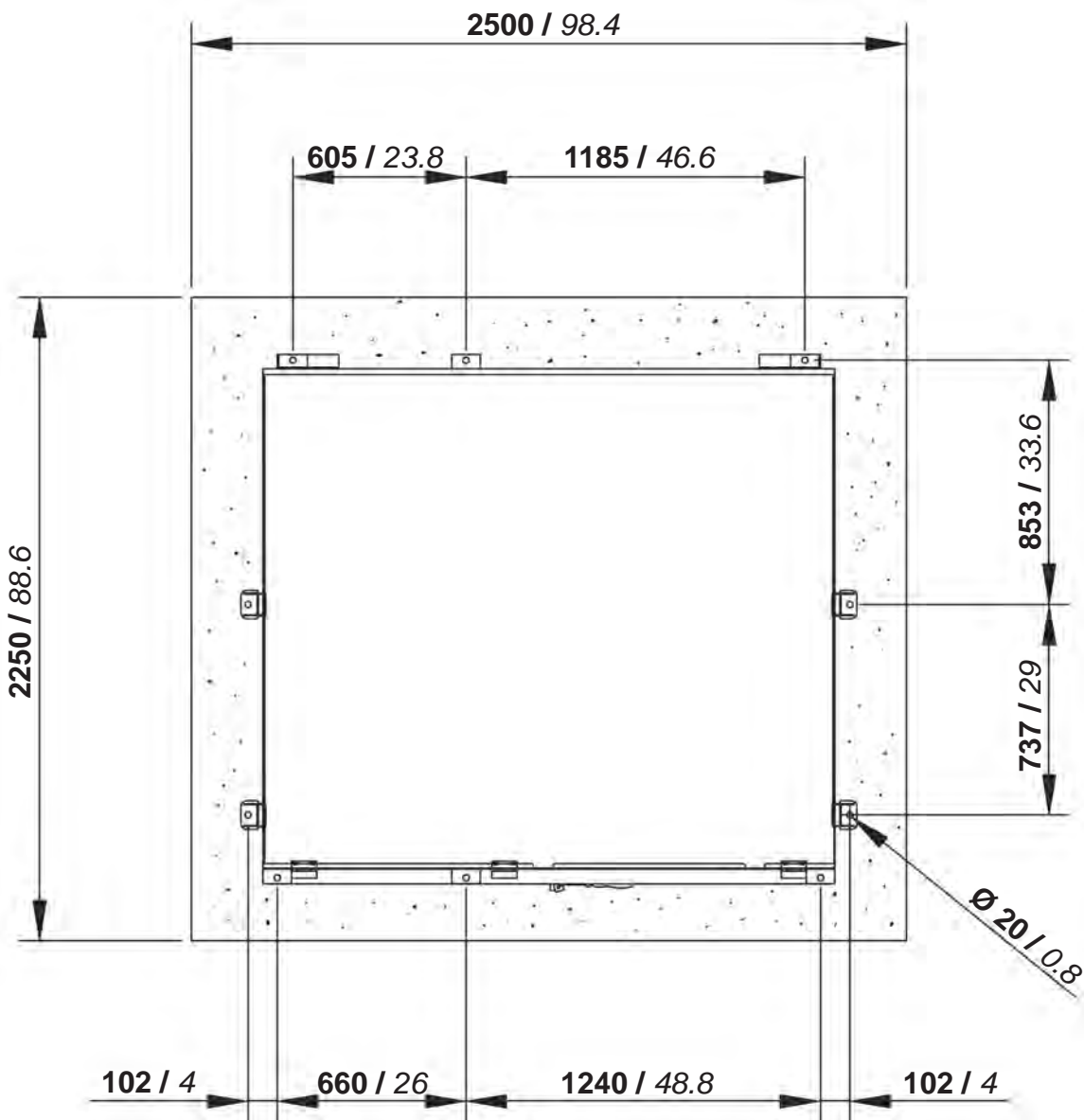
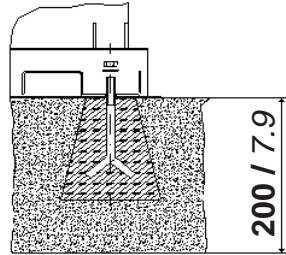

mm / inches



CONNECTIONS

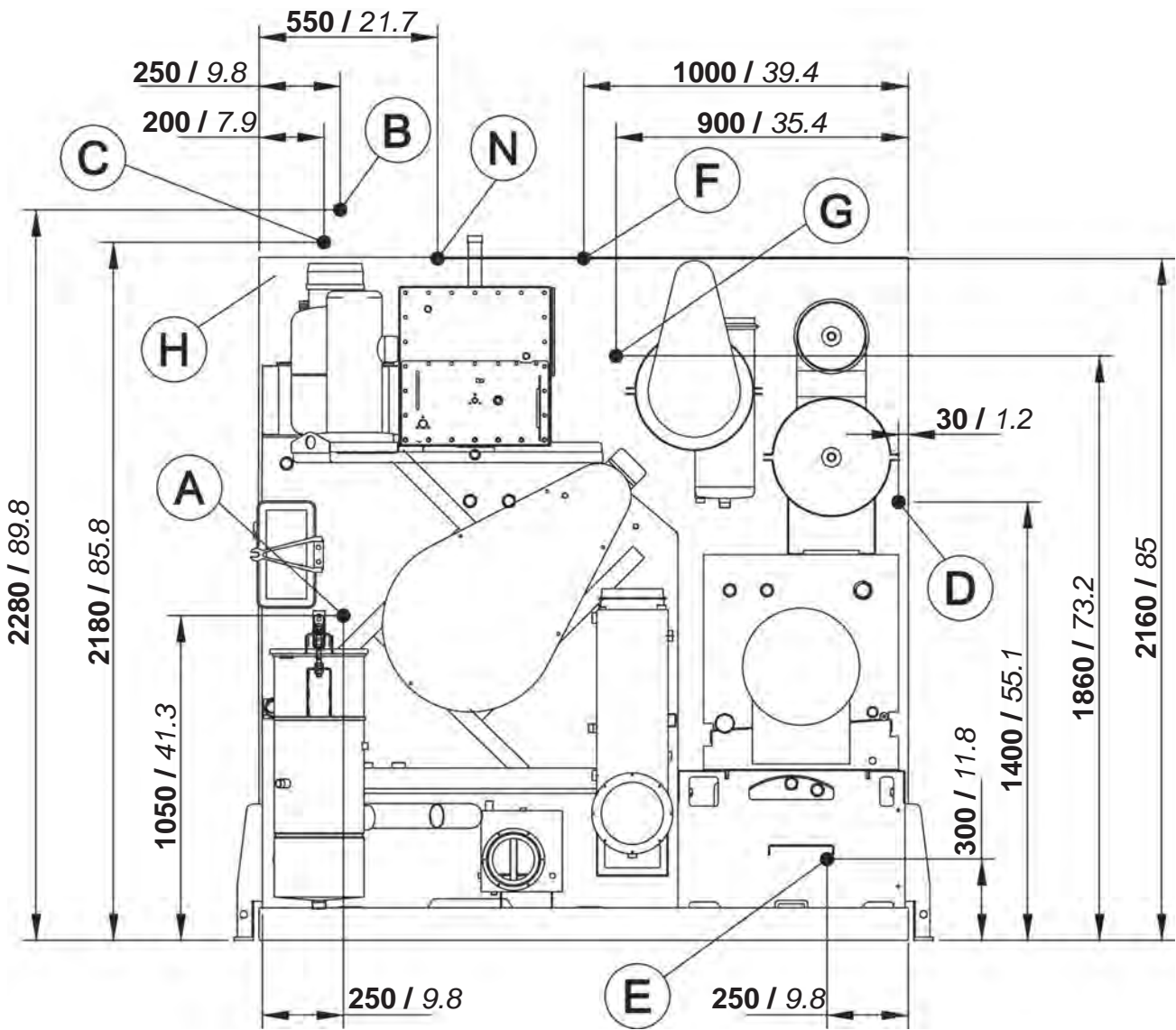

mm / inches

A	Compressed air inlet	Ø 6mm	Ø 1/4"
B	Water inlet	Ø 3/4"	
C	Water outlet	Ø 3/4"	
D	Steam still inlet	Ø 1/2"	
E	Condensate still outlet	Ø 1/2"	
F	Steam heater inlet	Ø 1/2"	
G	Condensate heater outlet	Ø 1/2"	
H	Electric connection		
N	Nitrogen feeding connection (N ₂)		



NECESSARY QUANTITY OF SOLVENT TO FILL THE MACHINE				
Machine version - without Filters	290 Lt	223 Kg	<i>77 gal</i>	<i>492 Lbs</i>
Machine version - 1 Nylon Filter	345 Lt	266 Kg	<i>91 gal</i>	<i>586 Lbs</i>
Machine version - 1 Nylon Filter + 1 KR	400 Lt	308 Kg	<i>106 gal</i>	<i>679 Lbs</i>
Machine version - 2 Nylon Filters	400 Lt	308 Kg	<i>106 gal</i>	<i>679 Lbs</i>
Machine version - 1 Nylon Filter + 1 Deco	358 Lt	276 Kg	<i>95 gal</i>	<i>608 Lbs</i>
Machine version - 1 Nylon Filter + 1 KR + 1 Deco	413 Lt	318 Kg	<i>109 gal</i>	<i>701 Lbs</i>
Machine version - 2 Nylon Filters + 1 Deco	413 Lt	318 Kg	<i>109 gal</i>	<i>701 Lbs</i>
Machine version - 2 Nylon Filters + 2 Deco	426 Lt	328 Kg	<i>113 gal</i>	<i>723 Lbs</i>

INFORMATION FOR THE ELECTRICAL CONNECTIONS (400V - 3~50Hz)		
ELECTRIC Version	33.5 Kw	58 Amp
STEAM Version	9.5 Kw	22 Amp
Dissipated heat	6000 Kcal	

INFORMATION FOR THE ELECTRICAL CONNECTIONS (220V - 3~60Hz)		
ELECTRIC Version	<i>- Kw</i>	<i>- Amp</i>
STEAM Version	<i>10.5 Kw</i>	<i>40 Amp</i>
Dissipated heat	<i>- Kcal</i>	

GENERAL INFORMATION		
Required water capacity	10 Lt/min	<i>2.6 gal/min</i>
Required water pressure	2 ÷ 3 bar	<i>29 ÷ 44 psi</i>
Required water temperature	18 ÷ 23 °C	<i>65 ÷ 73 °F</i>
Required air pressure	7 ÷ 8 bar	<i>100 ÷ 115 psi</i>
Required steam still pressure (K4)	2.5 bar	<i>36 psi</i>
Required steam still pressure (Kw-G.E.-KTEX)	4 ÷ 5 bar	<i>55 ÷ 72 psi</i>
Required steam heater pressure	4 ÷ 5 bar	<i>55 ÷ 72 psi</i>
Required steam* availability	70 Kg/h	<i>154 Lbs/h</i>

* Relative values of dry saturated steam.

All technical data are subject to change without notice.